

ADDITIVE MANUFACTURING SURFACE FINISHING STUDY

BENCHMARK OF SURFACE FINISHING PROCESSES FOR METAL AM COMPONENTS



FREE
EXCERPT OF
STUDY
AVAILABLE

SURFACE FINISHING STUDY

STATEMENT OF THE PROBLEM

Current Situation

- Which processes are suitable for our components?
- What are strengths and weaknesses of the processes?
- Which component properties are achievable?
- Which surface finishing is achievable?
- What are costs of the processes?

Solution

A study of the relevant surface finishing processes

- Objective comparison of different processes
- No expertise needed
- Quick decision on the most appropriate surface finishing processes for your component

STUDY CONTENT AND STRUCTURE

Materials investigated	Benchmark criteria
Titanium (Ti-6Al-4V)	Surface roughness
Aluminium (AlSi10Mg)	Surface hardness
Stainless Steel (1.4404)	Erosion rate
	Edge rounding
	Penetration depth



Processes to be investigated

Machining with undefined cutting edge

- **Abrasive Blasting**
- **Vibratory Finishing**

Finishing with chemical additives

- **Isotropic Superfinishing**
- **Micro Machining Process (MMP)**
- **Chemical Polishing**

Finishing with electric power

- **Electro Polishing**
- **Metal DryLyte**

Solidification with undefined cutting edge

- **Shot Peening**

More processes to be added in the future.

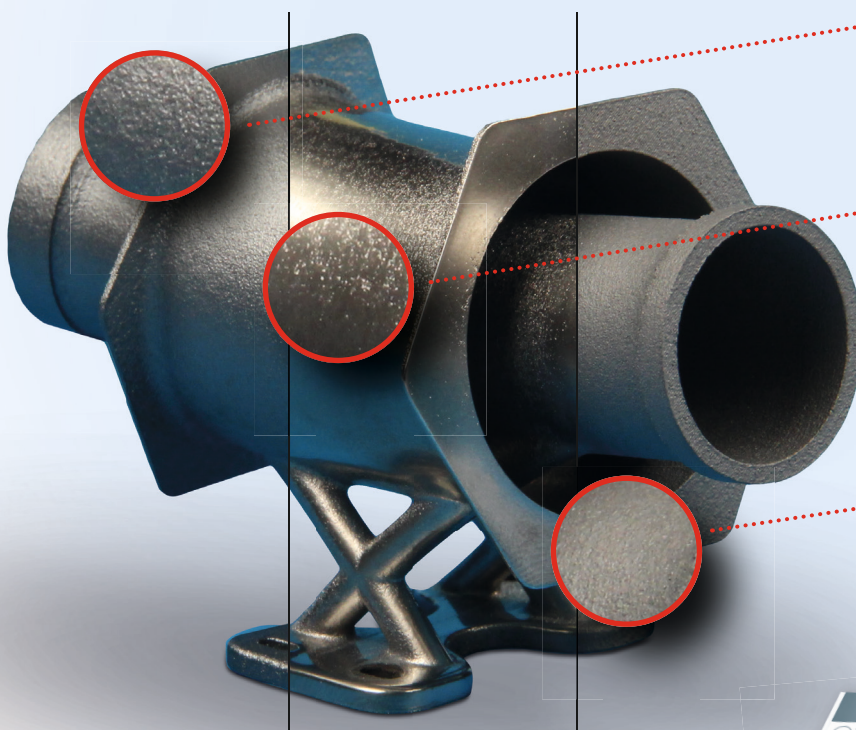

CONTACT FOR FREE EXCERPT

Order free excerpt of the study with benchmark results by
surface.finishing@iapt.fraunhofer.de

